

Gates Technical

The construction of our bespoke gates can be changed in a variety of ways to match your requirements. Shown on these pages are a number of options to consider, which can be used by you when discussing your project needs with our sales and estimating team.

Gate Configuration – Plan View

Double Leaf

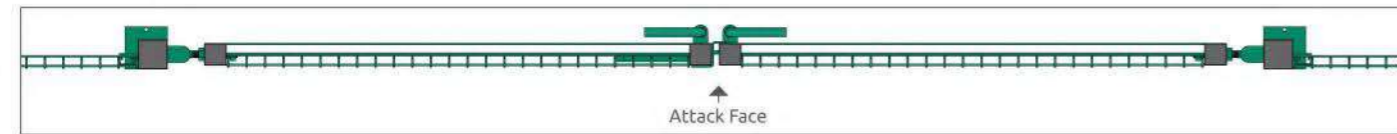

Single Leaf: Left-hand hanging

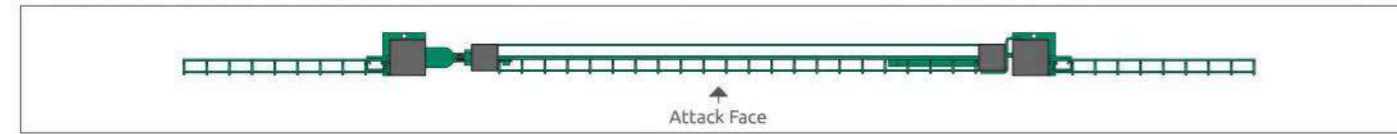

Single Leaf: Right-hand hanging

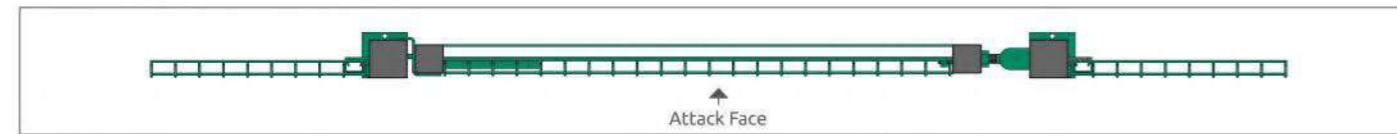

Gate Leaf Position with Post

Flush With Front (Preferred Option)

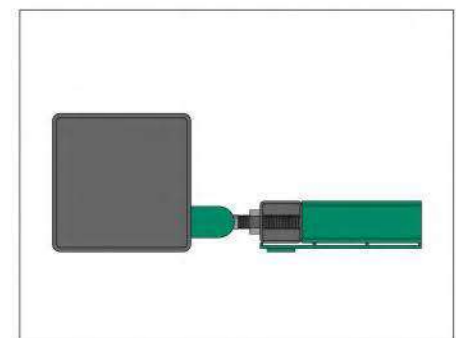

Centre

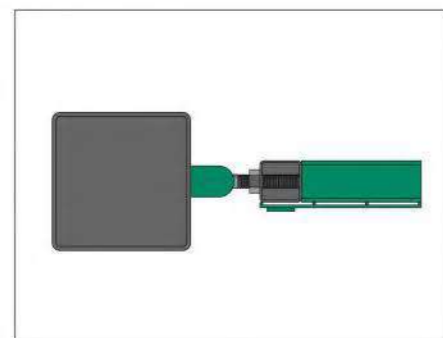

Pushed to Back

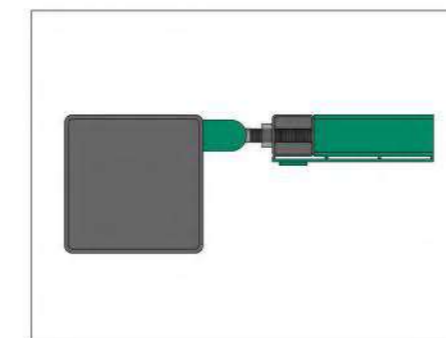

Hinge Swing Options

Opening in - 180°

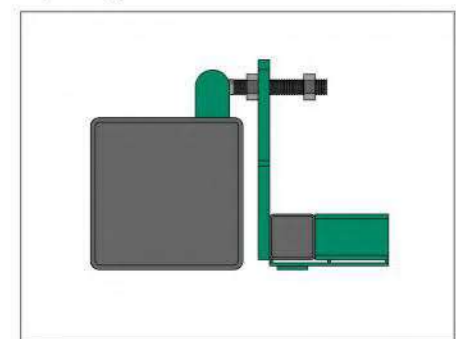

Opening in and out - 90°

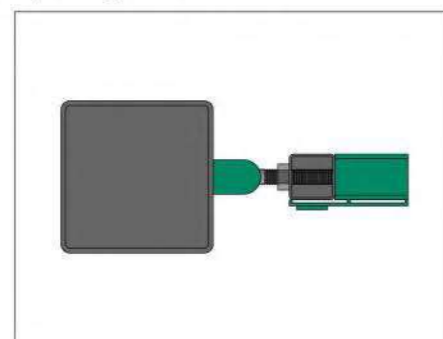

Opening out - 180°

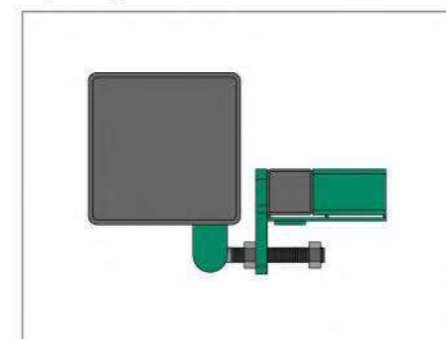

Mesh Configuration in Relation to Gate

(Hinge position can be adjusted to line through with mesh)

Left Hand Post

Lugged front and back

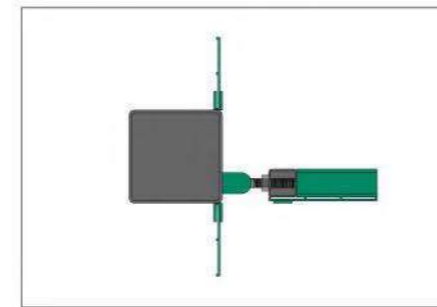

Lugged in line with mesh

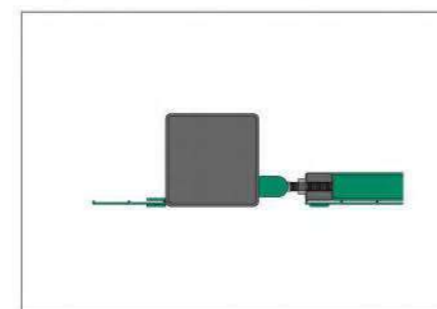

External corner/ lugged to back

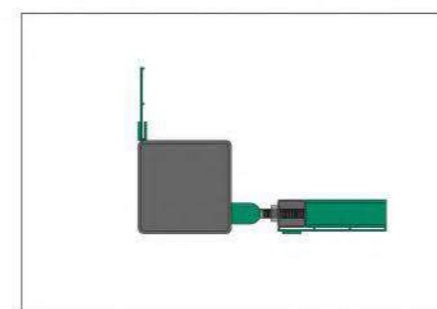

Internal corner/ lugged to front

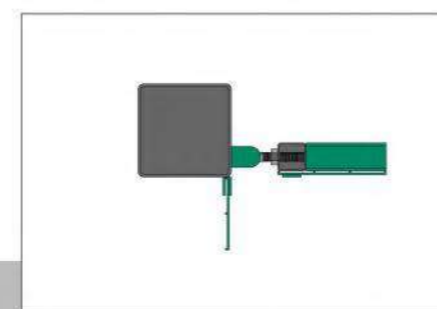

Right Hand Post

Lugged front and back

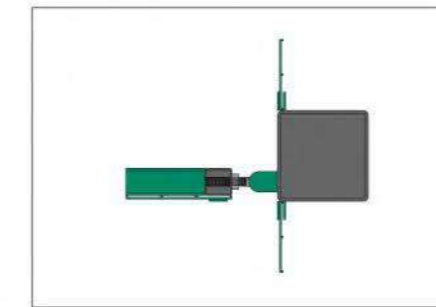

Lugged in line with mesh

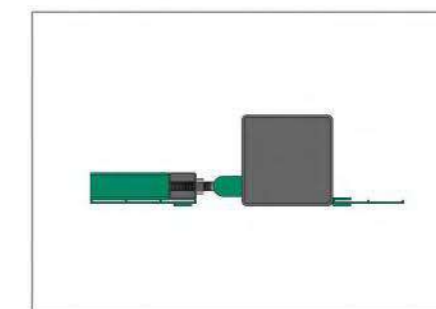

External corner/ lugged to back

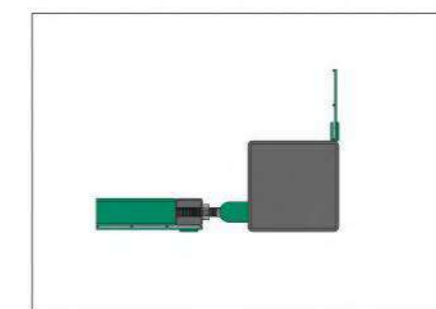

Internal corner/ lugged to front

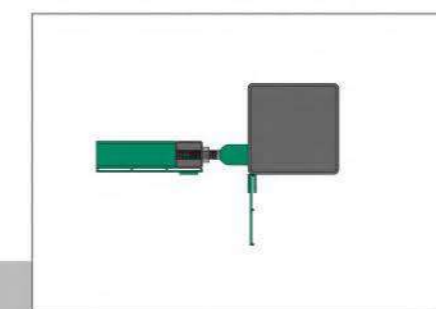

If you have a special project that requires a solution not covered by the above, please contact our estimating team to discuss how we can best achieve your goals. All our project work is supported with bespoke CAD drawings